



# FTJ & FTK Function Module(s)

## Single & Dual Channel MIL-STD-1553/1760 Communications Interface

### Description

The FTJ & FTK function modules provide a single and dual channel (respectively) dual-redundant MIL-STD-1553 communications interface with MIL-STD-1760 compatibility. MIL-STD-1553 (1553) is a military standard digital internal time division command/response multiplex data bus. MIL-STD-1760 (1760) includes additional communication and the electrical interface requirements for subsystems connected to the data bus for integration into weapon systems. MIL-STD-1553 applications have extended to systems integration of flight controls, propulsion controls, and vehicle management (electrical, hydraulic, environmental control, etc.) and MIL-STD-1760 extends this application base to DOD aircraft weapons store electrical interconnection systems.

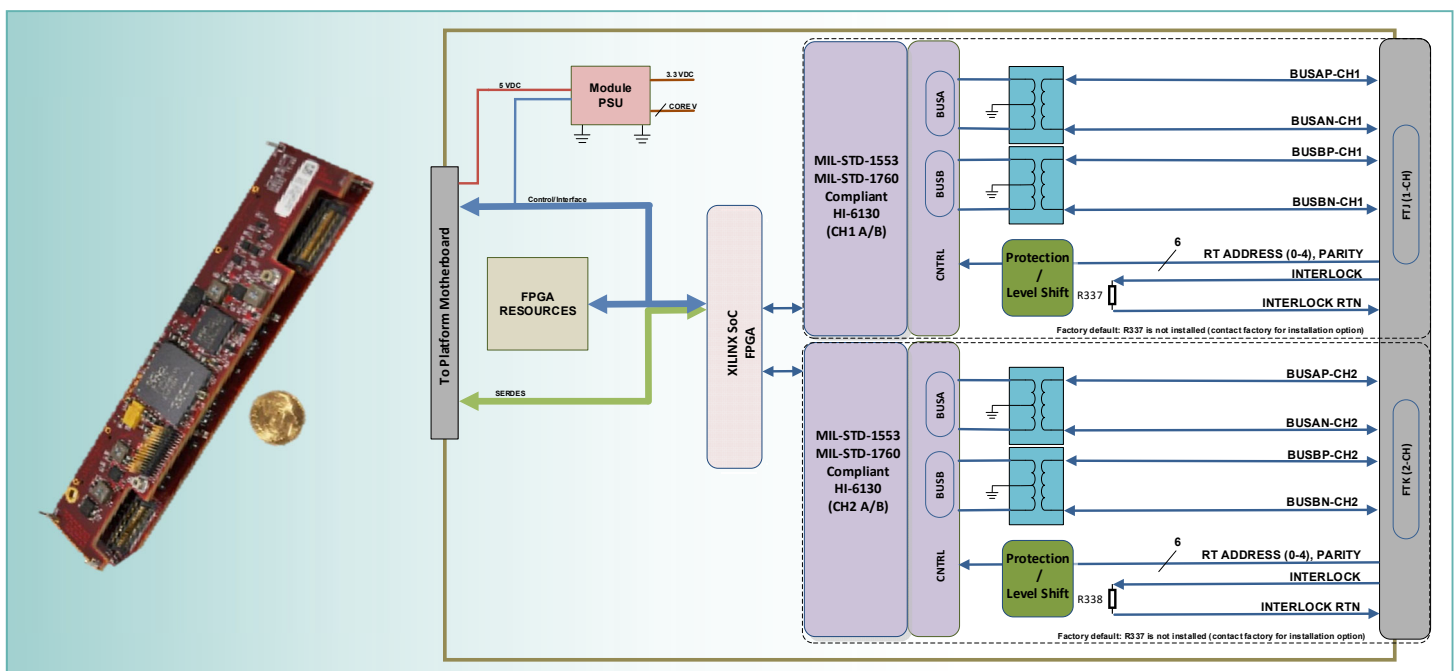

### Features Summary

- **MIL-STD-1553 AIRCRAFT INTERNAL TIME DIVISION MUX DATA BUS**
- **MIL-STD-1760 AIRCRAFT/STORE ELECTRICAL INTERCONNECTION SYSTEM Compatibility**
- **Channel Capacity; Transformer Coupled**
  - FTJ = 1 Channel, Dual Redundant
  - FTK = 2 Channels, Dual Redundant
- **Channel Operation Mode (programmable):**
  - Bus Controller (BC)
  - Remote Terminal (RT)
  - Bus Monitor (BM)
- **MIL-STD-1760 Compatibility**
  - Dedicated Holt-6130 transceiver for each channel
  - Meets MIL-STD-1760 signal requirements
  - Onboard EEPROM (per channel) for BC, RT or BM auto-initialization on power-up or reset.
    - EEPROM is user-programmable.
    - When auto-initialized as RT, channel(s) can respond within 150 msec.
    - Post-initialization, application software is capable of intervening after the operating system boots up on the onboard processor.
- **64k bytes of on-chip RAM per channel**
- **RT Address and Parity**
  - Hardwired (contact factory for additional 'lock-out' safety options)
  - Each channel checks for odd parity and is set via external address lines. RT Address is latched on boot-up or reset. No RT Address programming by the host.
- **Interlock**
  - Circuit path provided for Interlock and Interlock return.

### Specifications, General

<b>Number of Channels:</b>	FTJ: 1; (Transformer-Coupled) FTK: 2; (Transformer-Coupled)
<b>IP Core:</b>	HOLT IP-core register compatible/hardware acceleration for rapid setup, transmission and/or reception of packets.
<b>Transceiver</b>	Integrated Holt 6130 (family)
<b>Onboard RAM:</b>	64k words onboard memory per channel
<b>Operational Modes:</b>	Bus Controller (BC), Remote Terminal (RT), Bus Monitor (BM), or BC/RT
<b>Output Signal:</b>	@ 28 Vp-p, as per MIL-STD-1553 & MIL-STD-1760
<b>Power:</b>	5 VDC @ 600 mA estimated at 100% duty cycle (TBV)
<b>Weight:</b>	1.5 oz. (42 g)

### Operating Features

The FTJ & FTK provide MIL-STD-1553 serial communications with MIL-STD-1760 interface compatibility. MIL-STD-1760 was developed primarily to address additional aircraft weapons stores management and as such, includes some special requirements. The FTJ & FTK includes additional design and operational parameters to address these special requirements. The FTJ & FTK meet the general operational requirements of operating within the general specifications of MIL-STD-1760 as applied to an integrated I/O function module.

#### MIL-STD-1760 signal requirements

Though based on the MIL-STD-1553 signal and interface backbone, MIL-STD-1760 defines some tighter tolerances on signal parameters. The FTJ & FTK include special designed Holt transceivers to ensure signal parameter operation and integrity.

#### First communication

The FTJ & FTK provide a user-programmable EEPROM. When auto-initialized as an RT, the channel can respond on the bus with valid messages (as defined by the 1760 standard) containing pre-defined data (per sub-address) within 150 msec. of power-on per the MIL-1760 specification requirement (measured typical response is within 100 msec.).

#### RT Address Interface

Five binary weighted address lines plus one parity line and a common return line, are provided. They are used to assign the store's MIL-STD-1553 terminal address, between 0 and 30, for data bus communication. Each channel has its own set of hardwired RT address signal pins. Each channel checks for odd parity and is set via external address lines. RT Address is latched on boot-up or reset. Contact factory for special hardware override to lockout host software address programming (RTxLOCK option).

#### Interlock

A low impedance Interlock and Interlock RTN circuit path option is provided for the module for those application requiring a continuity path. Interlock and other identified Discrete signals are expected to be monitored and/or controlled by other means depending on the safety requirements of the aircraft. Contact factory.

### Architected for Versatility

NAI's Configurable Open System Architecture™ (COSA®) offers a choice of over 70 smart I/O, communications, or Ethernet switch functions, providing the highest packaging density and greatest flexibility of any 3U SBC in the industry. Preexisting, fully-tested functions can be combined in an unlimited number of ways quickly and easily.

### Background Built-In-Test (BIT)

BIT continuously monitors the status of all I/O during normal operations and is totally transparent to the user. SBC resources are not consumed while executing BIT routines. This simplifies maintenance, assures operational readiness, reduces life-cycle costs and - *keeps your systems mission ready*. Note: FTJ & FTK incorporate only standard user invoked loop-back mode.

### One-Source Efficiencies

Eliminate man-months of integration with a configured, field-proven system from NAI. Specification to deployment is a seamless experience as all design, state-of-the-art manufacturing, assembly and test are performed - by one trusted source. All facilities are located within the U.S. and optimized for high-mix/low volume production runs and extended lifecycle support.

### Product Lifecycle Management

From design to production and beyond, NAI's product lifecycle management strategy ensures the long-term availability of COTS products through configuration management, technology refresh and obsolescence component purchase and storage.



Made in the USA  
Certified Small Business

*All specifications are subject to change without notice. All product and company names are trademarks or registered trademarks of their respective holders*